

# 6.302 Feedback Systems

Recitation 17: Black's Formula Revisited, and Lead Compensation

Prof. Joel L. Dawson

By now, applying Black's Formula to a feedback system is almost a reflex:

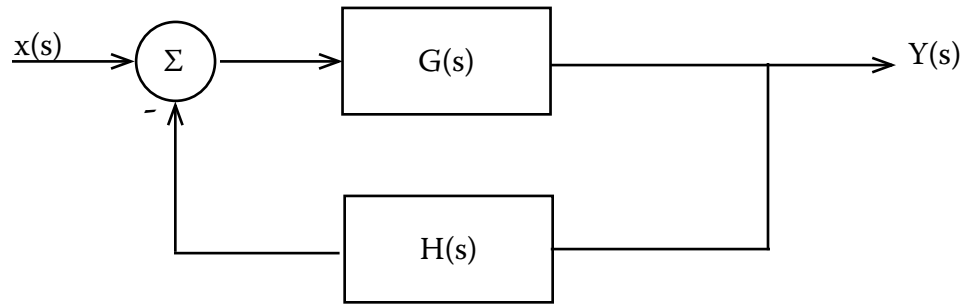

This formula actually lends itself rather naturally to graphical interpretation. Consider three different regions for the magnitude of  $L(s)$  [=  $G(s)H(s)$ ].

1)  $|L(s)| \gg 1$

Here  $|G(s)H(s)| \gg 1 \rightarrow |G(s)| \gg \frac{1}{|H(s)|}$

and the closed-loop transfer function is well approximated by

$$\frac{Y(s)}{x(s)} \approx \frac{1}{H(s)}$$

2)  $|L(s)| \ll 1$

Here  $|G(s)H(s)| \ll 1 \rightarrow |G(s)| \ll \frac{1}{|H(s)|}$

and the closed-loop transfer function is well approximated by

$$\frac{Y(s)}{x(s)} \approx G(s)$$

3)  $|L(s)| = 1$

This is how things are at the loop crossover frequency. At this point:

$$|G(s)H(s)| = 1 \rightarrow |G(s)| = \frac{1}{|H(s)|}$$

# 6.302 Feedback Systems

Recitation 17: Black's Formula Revisited, and Lead Compensation

Prof. Joel L. Dawson

The graphical interpretation goes as follows. To quickly graph the closed-loop response of a feedback system, we just overlay a plot of  $|G(s)|$  on top of a plot of  $|H(s)|^{-1}$ . The closed-loop curve is given by tracing the lower curve at all frequencies! And...loop crossover occurs at the intersection of the two curves.

EXAMPLE: Dominant-pole compensated op-amps.

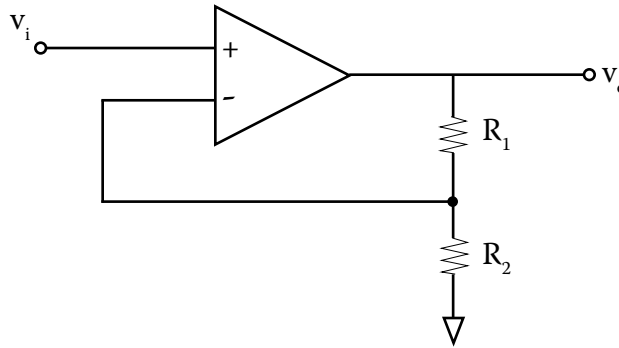

$$a(s) = \frac{10^6}{s + 1}$$

$$F = \frac{R_2}{R_2 + R_1}$$

Block Diagram:

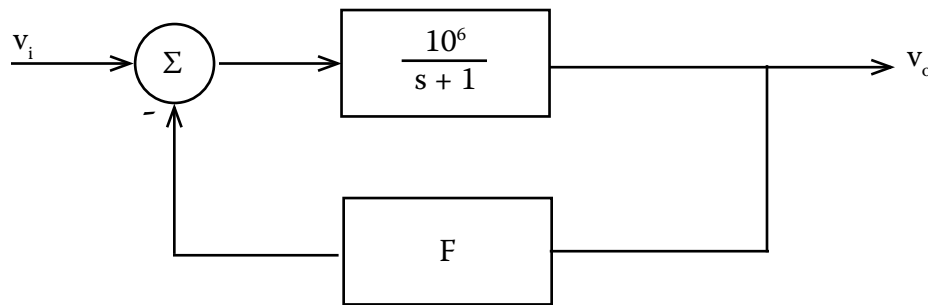

Bode Plots:

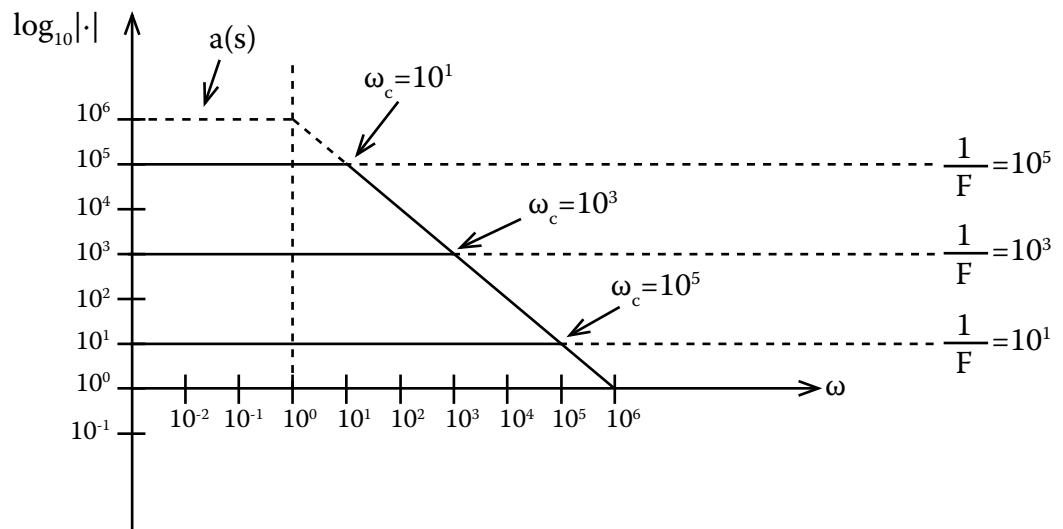

Notice: Gain-Bandwidth Product =  $\frac{1}{F} \omega_c = \text{constant for } \frac{1}{|F|} < 10^6$ .

This is not a fundamental law, but a reflection of the first order roll-off of the dominant-pole compensated op-amp.

# 6.302 Feedback Systems

Recitation 17: Black's Formula Revisited, and Lead Compensation

Prof. Joel L. Dawson

## Wrap-up of Lag Compensation

In the last recitation we covered lag compensation. In general, it is used in one of two ways.

- 1) Decrease  $|L(s)|$  at high frequencies, while leaving low-frequency behavior unchanged:

$$G_c(s) = \frac{\tau s + 1}{\alpha \tau s + 1}$$

- 2) Increase  $|L(s)|$  at low frequencies, while leaving high-frequency behavior unchanged:

$$G_c(s) = \alpha \left[ \frac{\tau s + 1}{\alpha \tau s + 1} \right]$$

Remember, it is the 3-degrees of freedom (pole placement, zero placement, and gain selection) that gave us an advantage over pure proportional control (pure gain selection).

## Lead Compensation

Lead Compensation reverses the order of the pole and zero. The general form here is

$$G_c(s) = k_L \left[ \frac{\alpha \tau s + 1}{\tau s + 1} \right]$$

And we tend to use lead compensation when we want one of three things:

- 1) By placing the lead zero at crossover (and the pole well above crossover), we can pick up  $45^\circ$  of phase margin without changing the crossover frequency.
- 2) By choosing a crossover frequency that falls at the geometric mean of the pole and zero, we can maximize our phase margin increase.
- 3) By using the lead zero to cancel a system pole, we effectively move that pole a factor of  $\alpha$  higher in frequency.

# 6.302 Feedback Systems

## Recitation 17: Black's Formula Revisited, and Lead Compensation

Prof. Joel L. Dawson

Let's see a couple of examples of lead compensation. Suppose that we've decided to let  $k_L = 1$ , so

$$G_c(s) = \frac{(\alpha\tau s + 1)}{(\tau s + 1)}$$

and the uncompensated system is

$$G(s) = \frac{10^8}{s^2}$$

for reasons of noise rejection, we will restrict ourselves to  $\alpha \leq 10$ . (This is not a hard and fast rule. We just want to put a flag in your mind about getting  $90^\circ$  phase bumps out of this technique.)

First, we'll place the lead zero at the old crossover,  $\omega_c = 10^4$ .

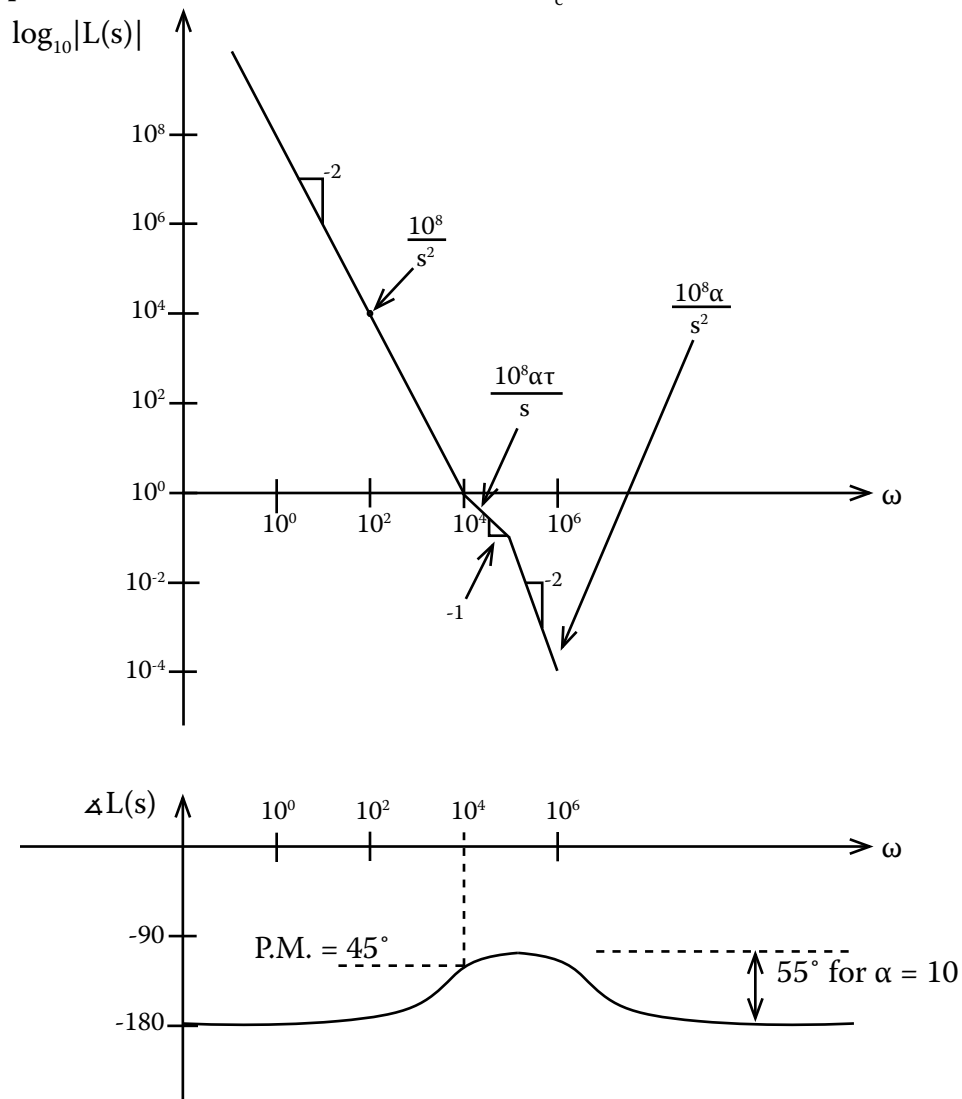

## 6.302 Feedback Systems

Recitation 17: Black's Formula Revisited, and Lead Compensation

Prof. Joel L. Dawson

Notice how, in the asymptotic approximation, the magnitude curve progresses as follows:

$$\frac{10^8}{s^2} \longrightarrow \frac{10^8 \alpha \tau s}{s^2} \longrightarrow \frac{10^8 \alpha \tau s}{s^2 \tau s}$$

$\omega$  increases

Useful picture for navigating around Bode Plots.

What about placing lead compensator such that we get the maximum phase bump to occur @ loop crossover?

In the vicinity of crossover, the loop transmission is going to look like

$$\frac{10^8}{s^2} \cdot \alpha \tau s = \frac{10^8 \alpha \tau}{s}$$

We require that the new crossover frequency be the geometric mean of the lead zero and lead pole frequency. That is

$$\omega_c = \sqrt{\frac{1}{\alpha \tau} \frac{1}{\tau}} = \frac{\alpha^{-1/2}}{\tau}$$

This allows us to solve for  $\tau$ :

$$L(j\omega_c) = 1 \rightarrow \frac{10^8 \alpha \tau}{\omega_c} = \frac{10^8 \alpha \tau}{\alpha^{-1/2} / \tau} = 1$$

$$10^8 \alpha^{3/2} \tau^2 = 1$$

$$\tau^2 = 10^{-8} \alpha^{-3/2}$$

$$\tau = 10^{-4} \alpha^{-3/4}$$

## 6.302 Feedback Systems

Recitation 17: Black's Formula Revisited, and Lead Compensation

Prof. Joel L. Dawson

Notice that we had to have the crossover frequency move from its original location. This happened because we have not used all of our degrees of freedom:

$$G_c(s) = k_L \left[ \frac{\alpha\tau s + 1}{\tau s + 1} \right]$$

If we use both  $k_L$  and  $\tau$ , we can get maximum phase bump and keep crossover the same.

Next time: Minor Loop Compensation

