

6.302 Feedback Systems

Recitation 20: Minor-Loop in an Op-Amp (continued)

Prof. Joel L. Dawson

This time, we're going to continue our discussion from last recitation concerning minor-loop compensation in op-amps. Let's first take a moment to remind ourselves of why we chose to do dominant-pole compensation in op-amps in the first place.

CLASS EXERCISE

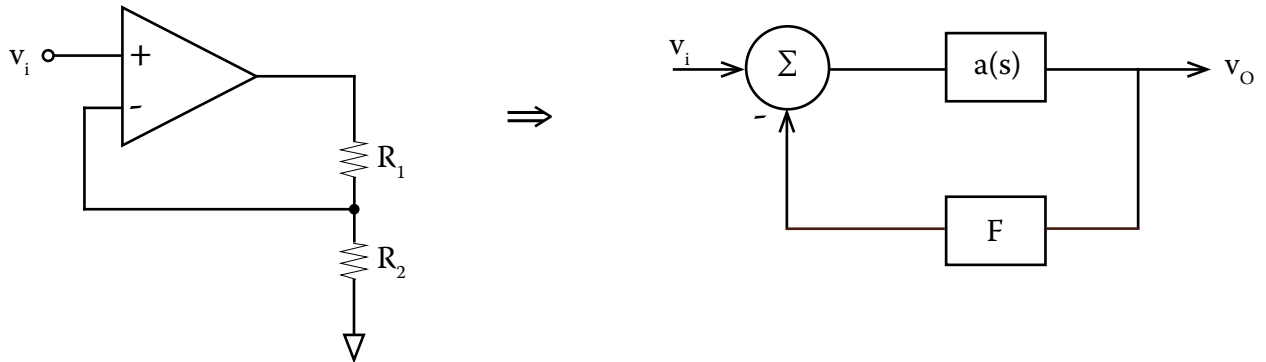

(a) If $a(s) = \frac{10^4}{(s+1)(10^{-4}s+1)}$, calculate the phase margin for $\frac{1}{F} = 100$, $\frac{1}{F} = 10$, and $\frac{1}{F} = 1$.

(b) Repeat these calculations for $a(s) = \frac{10^4}{s}$.

(Workspace below)

6.302 Feedback Systems

Recitation 20: Minor-Loop in an Op-Amp (continued)

Prof. Joel L. Dawson

This exercise was designed to show one of the virtues of dominant-pole compensation: it allows the user to use the op-amp as a programmable gain block (programmable through the choice of F) without having to worry about stability details. Most of you have built simple amplifiers this way long before you ever heard of Nyquist. In the op-amp that we look at now, the capacitor C_c causes the open-loop transfer function to look like $\frac{k}{s}$ over a broad range of frequencies.

Back to our example.

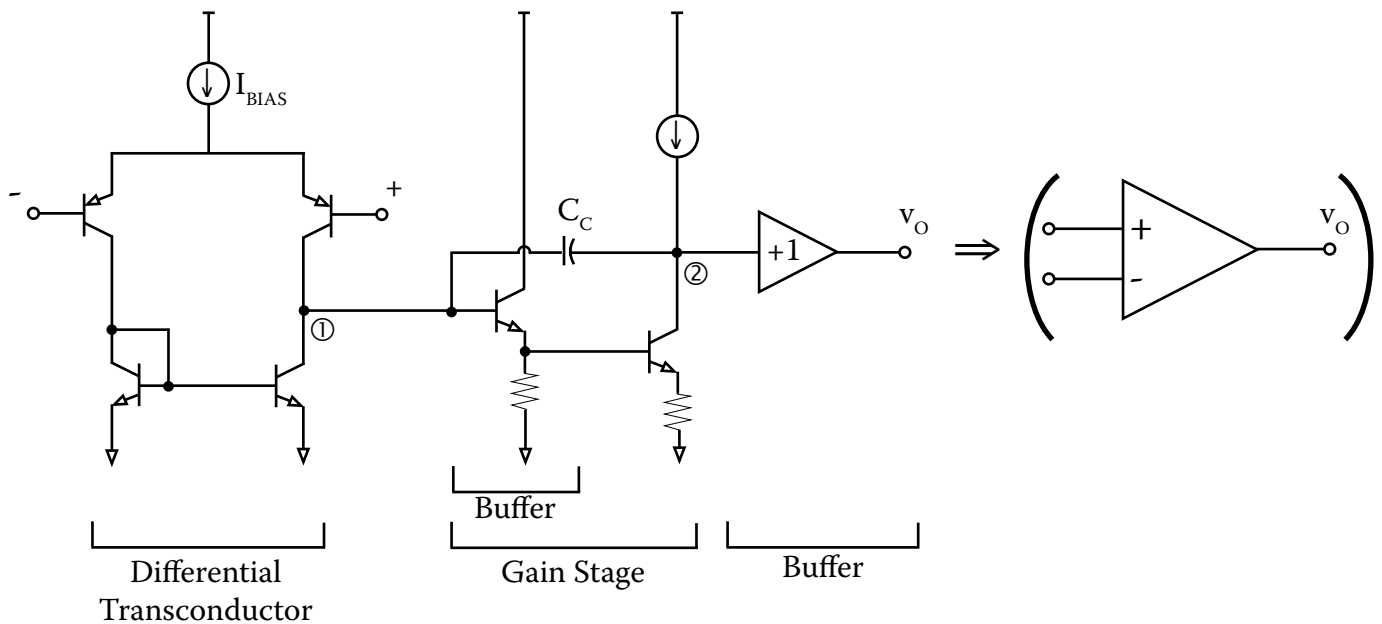

From last time, we decide that node ① is best treated as a virtual ground. \Rightarrow

6.302 Feedback Systems

Recitation 20: Minor-Loop in an Op-Amp (continued)

Prof. Joel L. Dawson

To analyze this we start by redrawing.

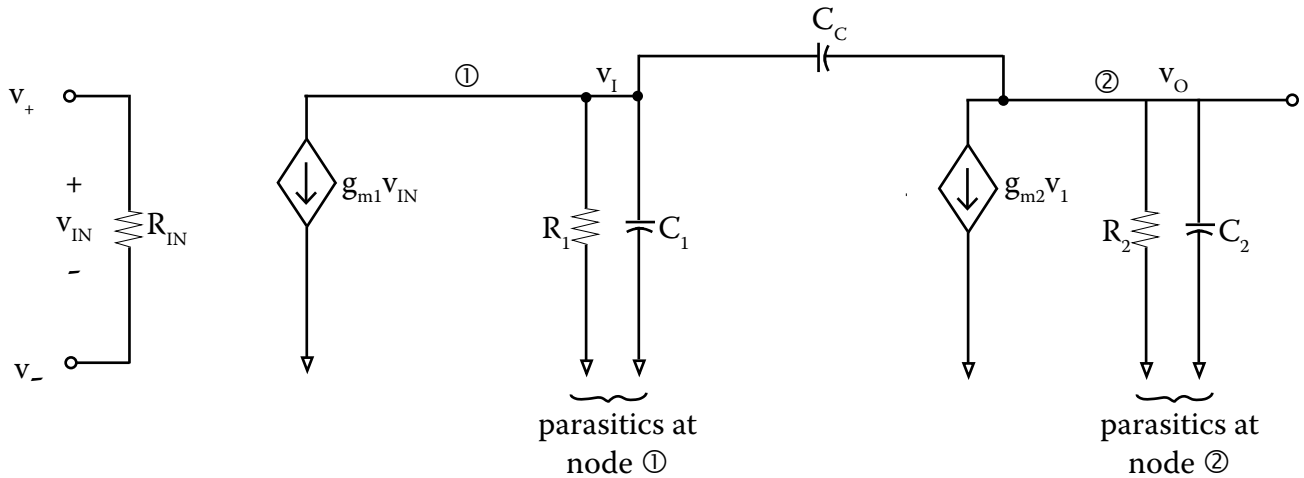

Now because node ① is a virtual ground, we can simplify our lives by replacing C_C with the ideal system block:

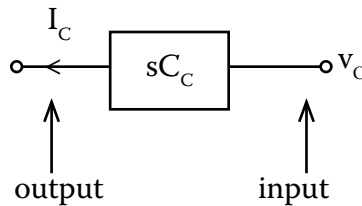

“Ideal” in what sense? Ideal in the sense that this block has infinite input impedance and, because it has a current output, infinite output impedance.

Now we have to do one more thing, which is to put back in the impedance loading effects that we took out when we went with an ideal system block. Here’s what I mean:

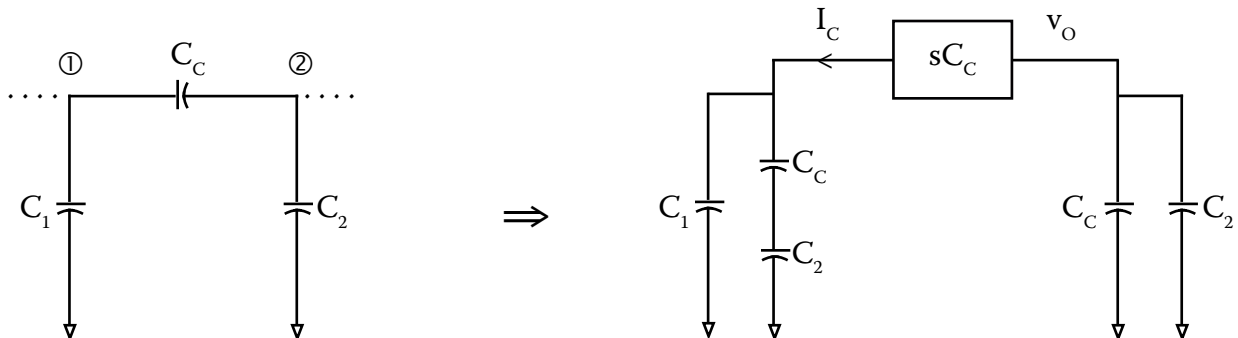

6.302 Feedback Systems

Recitation 20: Minor-Loop in an Op-Amp (continued)

Prof. Joel L. Dawson

Define $C_3 = C_1 + \frac{C_2 C_C}{C_2 + C_C}$
 $C_4 = C_2 + C$

And finally redraw one more time:

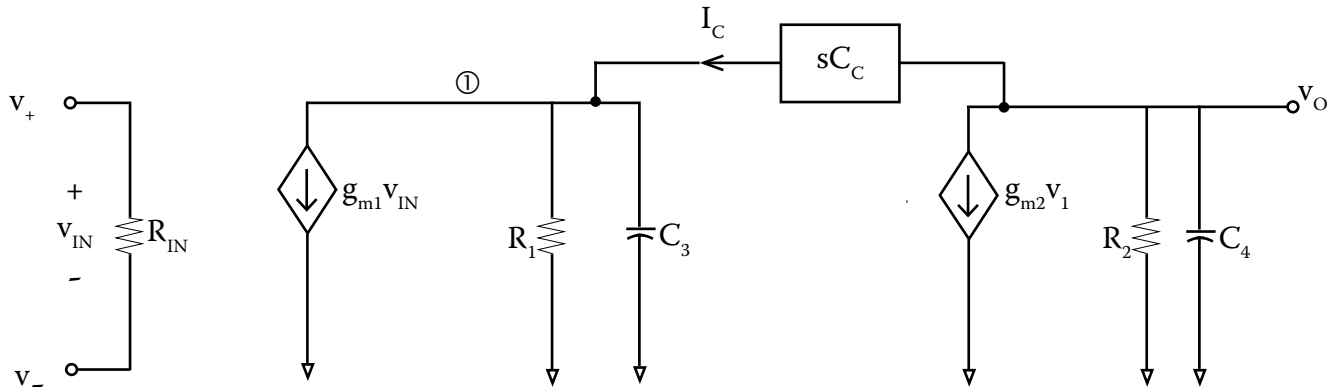

Doesn't look much easier to analyze, but it really is. First, combine R_1 and C_3 in a parallel combination:

$$R_1 \parallel \frac{1}{sC_3} = \frac{R_1}{R_1 C_3 s + 1} = Z_1$$

and

$$R_2 \parallel \frac{1}{sC_4} = \frac{R_2}{R_2 C_4 s + 1} = Z_4$$

Now the current flowing through Z_1 consists of two components: one due to v_{IN} , and one due to v_O . The voltage v_1 is the product of this current and Z_1 :

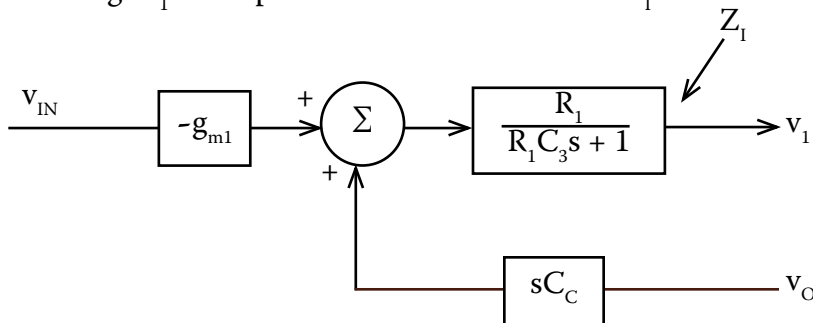

6.302 Feedback Systems

Recitation 20: Minor-Loop in an Op-Amp (continued)

Prof. Joel L. Dawson

Once we're this far, we're home free:

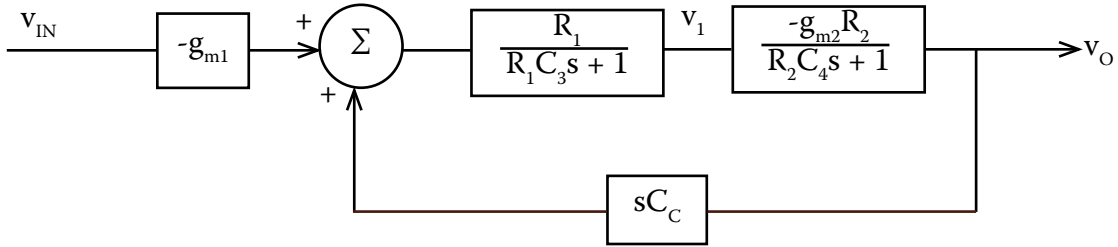

Okay. So what was it all for?! Why did we add compensation capacitor C_C ?

It turns out that without C_C , the open-loop transfer function of the op-amp looks more like part (a) of the class exercise. Changing the closed-loop gain would also change the stability margins, causing consternation among users.

But, by putting in compensation capacitor C_C , look what our open-loop transfer function approximates over a wide range of frequencies:

$$\frac{v_{OUT}}{v_{IN}} = \frac{g_{m1}}{sC_C} = a(s)$$

Just like in part (b)! Minor-loop compensation has helped us.

